

Mazda MZR 1.6L X-beam Connecting Rods Main Sizes

Brand: Hurricane *	
Center to Center Length: 135mm/5.315"	
Big End Bore Diameter: 51mm/2.008"	
Big End Width: 21.87mm/0.861"	
Small End Bore Diameter: 19mm /0.748"	
Small End Width: 21.87mm/0.861"	
Beam Style: X-beam	

Mazda MZR 1.6L X-beam Connecting Rods Features

Connecting Rod Bolt Diameter	3/8"
Approximate Connecting Rod Weight	XXXg
Advertised Horsepower Rating	600hp
Quantity	Sold as 4 pieces /set
Material	Forged 4340 steel
Connecting Rod Finish	Shot-peened, Polished
Pin	Bronze wrist pin bushings
Wrist Pin Style	Floating
Cap Retention Style	Cap screw
Weight Matched Set	Yes ,Balanced +/- 1g
Magnafluxed	Yes
Private Label	Yes ,available
Custom design	Yes, accept

Additional Description :

1. Precision-machined and fully inspected at Hurricane factory .

2. Each rod bronze wrist pin bushings installed for increased wear resistance .
3. Oil hole finished at their small ends to provide additional lubrication and cooling .
4. Various design is available, X-beam, H-beam , I-beam....



5. Heat-treated to 34-38HRC .
6. Lasering private label service provided .

7. Suits for Standard ARP 2000 rod bolts .

8. [Custom service](#) is available .



Hurricane Speed & Performance - Custom Connecting Rod Form

SPECIEF UNITS: _____ MM OR IN

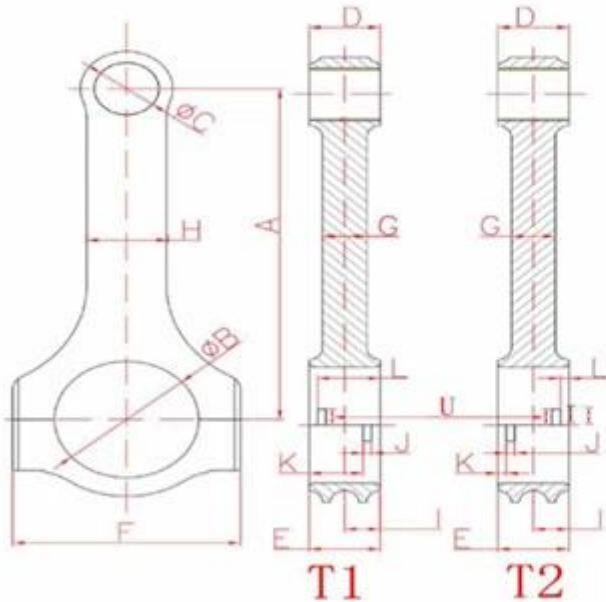

- | | |
|-----------------------------|-------------------------|
| A. _____ | B. _____ |
| Center to Center length/中心距 | Big End Bore/大孔 |
| C. _____ | D. _____ |
| Pin End Bore/小孔 | Pin End Width/小轴厚度 |
| E. _____ | F. _____ |
| Big End Width/大轴厚度 | Overall BE Width/肩宽 |
| G. _____ | H. _____ |
| Beam Thickness/杆厚 | Beam Width/杆宽 |
| I. _____ | S. _____ |
| BE Offset | T1 Or T2 反瓦/正瓦 |
| K. _____ | J. _____ |
| Tang Position | Tang Width/瓦槽宽度 |
| V. _____ | L. _____ |
| Tang Depth/瓦槽深度 | Tang Position |
| U. _____ | M. _____ |
| Tang Length/瓦槽长度 | H-beam X-beam I-beam/设计 |
| O. _____ | N. _____ |
| Piece/Set 只/组 | Engine Model/发动机型号 |
| P. _____ | Q. _____ |
| Bolt Diameter(Inch)/螺栓规格 | Piece (Quantity)/数量 |
| R. _____ | |
| Bolt Length(Inch)/螺栓长度 | |



The Process Of Custom Conrods

If we OEM your style of connecting rod , please follow the steps as below:

- 1). Providing detailed drawing , detailed dimenisons or sample , then we make detailed quotation .
- 2). If you agree our quote , then we start to design drawing .
- 3). Each other confirm the drawing and deal order details .
- 4). All details confirmed , 30% deposit required , then we make sample for you to test if necessary.
- 5). After the goods prepared , balance before shipping , and shipment arranged once payment is received .

Please feel free to [contact us](#) and discuss more if any further question .