

Brand: Hurricane  
 Engine: VW/AUDI 1.8T  
 Part Type: Connecting Rods  
 Center to Center Length: 144mm/5.670"  
 Big End Bore Diameter: 50.6mm /1.992"  
 Big End Width: 24.95mm/0.982"  
 Small End Bore Diameter: 20mm/0.787"  
 Small End Width: 24.95mm/0.982"  
 Beam Style: H-beam  
 Connecting Rod Bolt Diameter: 3/8 "  
 Approximate Connecting Rod Weight: 560g/piece  
 Advertised Horsepower Rating: 750hp  
 Quantity: Sold as 4pieces /set  
 Material: Forged 4340 steel  
 Connecting Rod Finish: Shot-peened, Polished  
 Pin: Bronze wrist pin bushings  
 Wrist Pin Style: Floating  
 Cap Retention Style: Cap screw  
 Weight Matched Set: Yes ,Balanced +/- 1g  
 Magnafluxed: Yes  
 Private Label: Yes ,available  
 Custom design: Yes, accept

## Forged VW & Audi 144\*20 conrods Main Dimensions

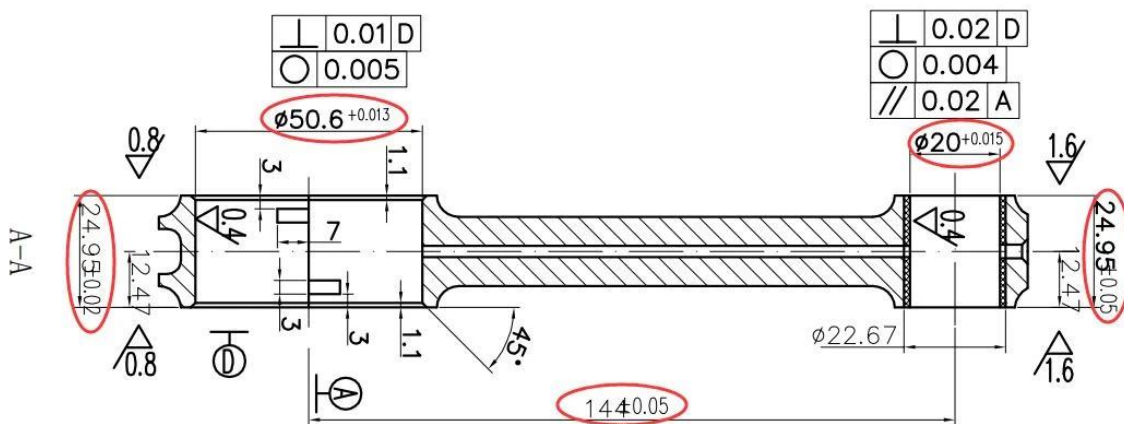

## VW 1.8T performance engine connecting rods Description & Advantages

Hurricane H-Beam VW/Audi 1.8T connecting rods are made from 1-piece chromoly steel forging to ensure maximum strength and durability. Material using high tensile [4340 steel/40CrNiMoA/EN24](#), 100% CNC machined. Surface looks very smooth and beautiful because of the polish and shot-peen process. We offer a huge connecting rod line to Audi/VW engines to all over the world.

### 1. 1-piece chromoly steel forging



**2. 100% CNC Machine, polished and shot-peened treatment.** The article you could explore, "[Hurricane High Performance connecting rods - Process of machining rods](#)".

**3. Newest package protect rods, no matter what kind of shipping way.**





Put forged connecting rod into yourself racing car .

